

TECHNIQUES AND NUCLEAR APPLICATIONS AROUND ES SALAM REACTOR, STATUS AND FUTURE POTENTIAL

M. SALHI, M. ABBACI, M. TOUIZA, F. RIAHI, S. LAOUAR
Centre de Recherché Nucléaire de Birine,
Ain-Oussera,
Algérie
mn_salhi@yahoo.fr

T. ZIDI
Commissariat à l'Energie Atomique,
Algiers,
Algérie

1. DESCRIPTION OF ES SALAM RESEARCH REACTOR

Es Salam is a multipurpose heavy water research reactor, cooled and moderated by heavy water and using graphite as the reflector. It is a tank type with a nominal power of 15 MW. Its maximum thermal neutron flux reaches $2.4 \times 10^{14} \text{ cm}^{-2}\text{s}^{-1}$ at the central irradiation channel position. The availability of a flat neutron flux and low nuclear heating in the heavy water and graphite reflector satisfy the requirements of several types of irradiation. The rather large core of Es Salam enables a high slow down of fast neutrons. Also, the thermal-to-fast neutron flux ratio is higher far from the core. Es Salam research reactor is designed to operate the three first weeks of the month and the last remaining week is reserved for maintenance.

The design of the reactor has been optimised to satisfy radioisotope production requirement, to supply high flux neutron beams for researchers and future expansion for development and application in vital areas. The reactor has a quite pure thermal-neutron spectrum and much more space available for arranging many vertical and horizontal channels. There are more than 40 dry vertical irradiation channels with 3 different diameters, 2 pneumatic irradiation devices which are dedicated to neutron activation analysis and delay neutron counting, 5 horizontal beam radial channels, and a thermal column. The reactor hall encloses enough space around the core shielding to allow the installation of some neutron scattering facilities that require low radiation background, without needs of neutron guides. The average neutron flux at the beam port of the horizontal channels is close to $10^7 \text{ cm}^{-2}\text{s}^{-1}$ at full power.

The tests, experiments and production of radioisotopes must be done according to the safety requirements. The experimenter must indicate in a protocol all parameters and possible changes made during irradiation. This protocol shall be checked and approved by the safety committee of the reactor. The supervisor of the reactor controls in coordination with the experimenter all the phases of the experiment.

2. REACTOR OPERATION AND INSTALLATION OF NUCLEAR APPLICATIONS

The training of groups able to master the different aspects of continuous running and management of the reactor and the facilities around it at full power was the main objective fixed before advancing nuclear applications projects and services to the industrial and scientific community. On the other hand, experimental and calculation physics of the reactor core, radiation

protection, thermal hydraulic calculation and nuclear engineering are also the parallel fields of focus in this phase of training.

In the vision to use the reactor for socio-economic development and satisfy the demand of universities and national research centres, several activities were conducted to perform existing techniques such as neutron activation analysis and to implement new nuclear application, especially in the neutron scattering and neutron transmutation domains. A number of technical cooperation projects with the IAEA were carried out. The purpose of these projects is the implementation of two axes powder neutron diffraction (see Figure 1) and neutron radiography facilities (see Figure 2) while also carrying out feasibility studies of neutron transmutation doping of silicon and prompt gamma neutron activation analysis. The Agency supports the projects by supplying heavy equipments (in-pile parts, out-of-pile parts and instruments of the diffractometer) and nuclear materials (for neutron imaging and NTD-Si). It also supports the visit and training of personnel in our and foreign laboratories.

The results issued from this project are the installation of two nuclear applications around the reactor and the constitution of competence in the design of neutron scattering and neutron irradiation facilities. The following table summarizes the history of development of different applications around the Es Salam reactor:

TABLE 1. APPLICATIONS AND THEIR EVALUATION AT THE ES SALAM RR

Applications	Task/activity	Success criteria
NAA	<ul style="list-style-type: none"> - Ensure long-term sustainability for NAA labs utilization for environmental, geological, industrial, and medical applications; - Establish the good practice guide; - Promotion of the technique by the publication of the results and the participation in national and international conferences and workshops; - Training on QA for NAA; - Improvement of the NAA by introducing other techniques such as k_0-NAA, RNAA and cyclic delayed neutron counting; - Participation in inter comparison studies; - Upgrade a part of NAA device by installing an advanced automated system. 	<ul style="list-style-type: none"> - Devices operable; - Results output (services and research and development); - Satisfy the incoming demand; - To make the NAA competitive; - Upgrading the NAA facilities in order to make it reliable and raise the rate of samples radiation and analysis.
Neutron Diffraction	<ul style="list-style-type: none"> - Master the exploitation of the system; - Produce a quality results (data treatment and refinement); - Upgrade the system by installation of cryostat 20K; - Optimisation of the variables parameters (divergence angles); - Renovation of the out-of-pile parts of the system; - Simulation of the diffractometer by appropriate software tools (VITNESS or McStas); - Identify the limitations of the system. 	<ul style="list-style-type: none"> - Acquire a knowledge in different step of the installation of neutron scattering facilities; - Qualification of the installation with standards; - Results output (services and research and development); - Analyse the magnetic properties of materials; - Make the system more reliable; - Validation of simulation results by experiments results; - Make reflection to overcome the limitations.
Neutron Imaging	<ul style="list-style-type: none"> - Training of personnel; - Characterisation of the beam; - Design and manufacture of in-pile and out-of-pile NI facility; - Qualification of the installation; - Extension of the NI facility to neutron tomography and dynamic neutron Imaging. 	<ul style="list-style-type: none"> - Acquire a know-how in the design of neutron collimator; - Have a non-destructive testing tool; - Results output (services and research and development); - Extend the application domain of the NI facility.
NTD-Si	<ul style="list-style-type: none"> - Choice and characterisation of silicon irradiation channel; - Personnel Training and IAEA expert visit; - Irradiation parameters calculation (physics, thermal hydraulic and induced radiation); - Design, manufacture and out-of-pile testing of 3inch diameter silicon prototype irradiation rig; - Design the in-core instruments and the command of the Si-rig; - Implementation of quality control laboratory and procedures of preparation and doping of silicon; - Wafers silicon doping and overcome the difficulties; 	<ul style="list-style-type: none"> - Succeed in irradiation and qualification of silicon wafers doped ; - Manufacturing of the irradiation rig and the auxiliaries; - Production of ingots doped silicon
PGNAA	<ul style="list-style-type: none"> - Constitution of reflection group to carry out a feasibility study; - Long-term training of personnel in laboratory. 	<ul style="list-style-type: none"> - Acquire knowledge in the PGNAA technique and the beam technology.

Through these activities, a multidisciplinary competence has been formed and has contributed to the achievement of the predicted applications, and they will positively take part in the future implementation of facilities around the experimental channels of our reactor.

The activities are now focused towards the production applications of ^{192}Ir sealed sources. This project was also conducted in cooperation with the IAEA. Two hot cells for post-irradiation of nuclear fuel have been converted to contain the equipment necessary for processing, which was provided by the Agency. The production of appropriately sealed sources is ongoing.

3. OPERATIONAL APPLICATIONS AND TRAINING AT ES SALAM REACTOR

3.1. NAA facilities

- Pneumatic system for short-lived elements NAA at a flux close to $1 \times 10^9 \text{ cm}^{-2} \text{ s}^{-1} \text{ kW}^{-1}$;
- Ordinary long-lived elements NAA at a flux close to $1 \times 10^{10} \text{ cm}^{-2} \text{ s}^{-1} \text{ kW}^{-1}$;
- Pneumatic system for DNC at a flux close to $1 \times 10^9 \text{ cm}^{-2} \text{ s}^{-1} \text{ kW}^{-1}$; and
- HPGe gamma detectors with recent software for data acquisition and treatment.

3.2. Neutron diffraction system

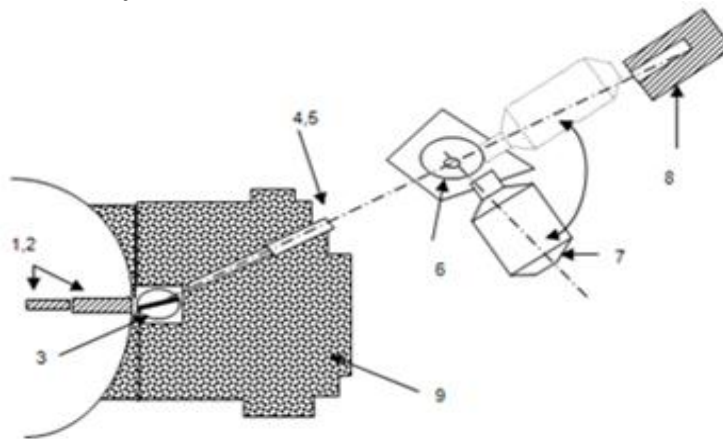

- 1, 2: Collimator with beam shutter
 3: Monochromator Pb(200)
 4: Secondary out pile beam tube and Soller collimator
 5: He-3 neutron flux beam monitor
 6: Sample table with helium liquefier (10 to 300K)
 7: He-3 detector
 8: Beam stop
 9: Biological shielding.

Fig. 1. Two axes powder neutron diffraction at Es Salam Reactor.

TABLE 2. ES SALAM NEUTRON DIFFRACTION SYSTEM CHARACTERISTICS¹

Neutron wavelength	1.45 Å
Neutron energy	37 MeV
Neutron flux on the sample	$1 \times 10^5 \text{ cm}^{-2} \text{ s}^{-1}$
Scattering angle	135°
Beam divergence	50°
Monochromator	Pb(200)
Neutron diffraction angle at Pb(200)	34°

¹ The operation of the system is done by PC.

3.3. Neutron imaging system

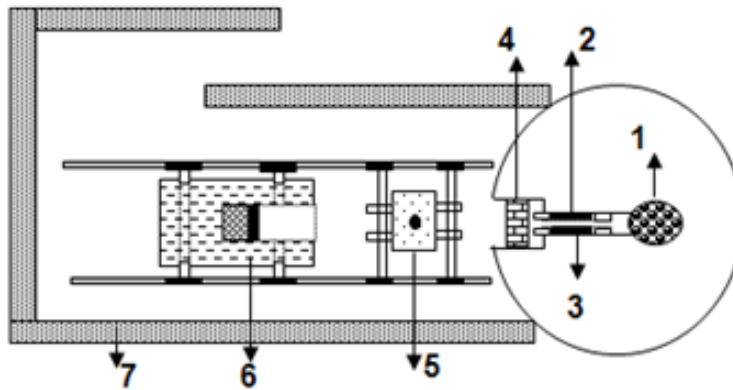

- 1: Reactor core
- 2: Experimental channel
- 3: Collimator
- 4: Beam shutter
- 5: Exposition table
- 6: Beam catcher
- 7: Biological shielding

Fig. 2. Neutron imaging facility at Es Salam reactor.

TABLE 3. ES SALAM NEUTRON IMAGING SYSTEM CHARACTERISTICS

Neutron flux on the sample	$1 \times 10^5 \text{ cm}^{-2}\text{s}^{-1}$
Collimator L/D	180
Cadmium ratio	83:1
Beam size	240 mm
Inlet aperture	20 m

3.4. Training

After it went critical in 1992, the Es Salam reactor served as a training school to provide training in the field of nuclear and reactor physics in order to contribute to the development of national expertise. Many graduate and undergraduate students can perform some of their experimental work using the capabilities of the reactor to fulfil their university requirements it is usually used to carry out training programs for reactor operators on the facility's operation

On the other hand, several conferences and workshops with topics in relation with the development and the use of nuclear techniques and their impact on socio-economic development were held.

3.5. Near future vision of production and services applications

The upgrading of the neutron diffractometer by installing a system of PSD bend detector, in order to reduce the acquisition time of spectrograms, the changing of the Pb(200) monochromator with

a silicon mono-crystal one, in order to analyze the residual stresses in materials, and the achievement of tomography facility are the main actions that are planned in the near future.

The success of the installation of Ir-192 production has encouraged us to initiate reflections on other radioisotopes.

The implementation of the PGNAA and the high-intensity positron source are the two proposed future nuclear applications. The feasibility studies are going on.

4. CONCLUSIONS

The potential of the Es Salam research reactor and its reliability of continuous operation according to the rules of safety and the feedback experience acquired through contributions in various R&D activities will certainly serve to support other advanced projects in the field of nuclear technology and applications

The upgrading of our application facilities is making our nuclear services more reliable and competitive with conventional methods. This has also permitted the increase in learning capacity.

5. ACKNOWLEDGEMENTS

Our sincere thanks must be sent to the IAEA and international experts who have contributed to the achievement and success of projects, and also our acknowledgement goes to the foreign laboratories that accept the scientific visits and the training courses of our personnel.